

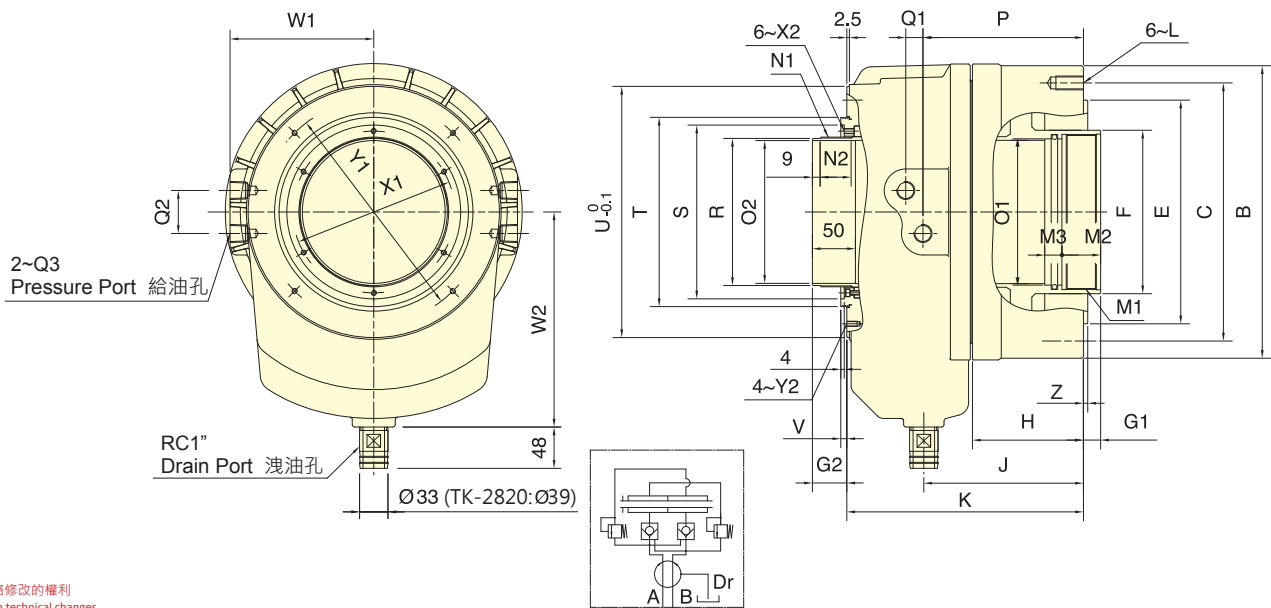

- 全新短型設計，大孔徑型迴轉油壓缸。
- 內建逆止閥自鎖機構及壓力洩壓閥。
- New design, short form, light weight large through-hole.
- Built-in safety check valves and pressure relief valves.

■ 專利產品字號 Patent numbers:
 台灣: PAT.NO.M491534(Taiwan)
 大陸: PAT.NO.ZL201420584274.5(China)



保留規格修改的權利
 Subject to technical changes

技術規格 SPECIFICATIONS

| 型號 Model | 活塞面積 Eff. piston area | | 行程 Piston stroke | 最高迴轉數 Max. speed | 最高使用壓力 Max. pressure | I Moment of inertia | 重量 Weight | 總洩漏量 Total oil leakage |
|-------------|--------------------------------|---------------------------------|---------------------|---------------------|-------------------------|------------------------|--------------|---------------------------|
| | 押側 (Extend) cm ² | 拉側 (Retract) cm ² | | | | | | |
| TK-2416 | 418.4 | 375.4 | 35 | 2000 | 3.0 (30) | 1.12 | 78.0 | 9.0 |
| TK-2416L | 418.4 | 375.4 | 51 | 2000 | 3.0 (30) | 1.31 | 79.2 | 9.0 |
| TK-2820 | 526.2 | 472.6 | 51 | 1600 | 3.0 (30) | 2.4 | 134.0 | 10.0 |

外型尺寸 DIMENSIONS

| Model | A 內徑 I.D. | B | C | E h7 | F | G1 | | G2 | | H | J | K | L | M1 | M2 | M3 | N1 | N2 |
|----------|-----------------|-----|-----|---------|-----|------|------|------|------|-----|-------|-----|--------|--------|----|----|--------|----|
| | | | | | | max. | min. | max. | min. | | | | | | | | | |
| TK-2416 | 290 | 340 | 300 | 260 | 190 | 35 | 0 | 60 | 25 | 129 | 185.5 | 275 | M16x32 | M180x3 | 45 | 20 | M174x2 | 38 |
| TK-2416L | 290 | 340 | 300 | 260 | 190 | 51 | 0 | 76 | 25 | 145 | 201.5 | 291 | M16x32 | M180x3 | 45 | 20 | M174x2 | 52 |
| TK-2820 | 340 | 395 | 360 | 320 | 235 | 51 | 0 | 76 | 25 | 152 | 212.5 | 316 | M20x40 | M220x3 | 45 | 20 | M218x2 | 52 |

| Model | O1 H8 | O2 H8 | P | Q1 | Q2 | Q3 | R g7 | S H7 | T | U | V | W1 | W2 | X1 | X2 | Y1 | Y2 | Z |
|----------|----------|----------|-------|-------|----|-------|---------|---------|-----|-----|-----|-------|-----|-----|-------|-------|-------|-------|
| | TK-2416 | 170 | 166 | 186.5 | 20 | 50 | RC1/2 | 171 | 202 | 220 | 292 | 7 | 167 | 250 | 188 | M6x11 | 260 | M6x12 |
| TK-2416L | 170 | 166 | 202.5 | 20 | 50 | RC1/2 | 171 | 202 | 220 | 292 | 7 | 167 | 250 | 188 | M6x11 | 260 | M6x12 | 6 |
| TK-2820 | 210 | 205 | 216 | 21 | 50 | RC1/2 | 215 | 262 | 285 | 360 | 7 | 202.5 | 300 | 240 | M6x12 | 320 | M6x12 | 6 |